

INSTALLATION INSTRUCTIONS

WARNING: DISCONNECT POWER BEFORE INSTALLING
DESUNA LA ELECTRICIDAD ANTES DE HACER REPARACIONES

Note: Automatic dryers are not recommended for hair drying use.

1. Removal of cover:

- A) Loosen tamper-proof screws using wrench supplied, turn **clockwise** (do not remove). Located under bottom intake vent.
 - B) To remove, place a hand on each side of cover and lift upward, then pull off.
2. Dryers should be placed at least 2 feet (61cm) apart and at least 12" (30cm) from washbasin. Do not install dryer over washbasin. Automatic dryers should be at least 18" (46cm) above any projection which may interfere with the operation of the automatic sensor.

Hold the backplate to the wall at the suggested mounting height. Measure from bottom edge of **backplate** to the **floor** (Ref. Dimension "A" Fig. 1):

	MEN	WOMEN	(depends on age)	DISABLED CHILDREN
A-T - Hand Dryer	42" (107cm)	40" (102cm)	30-40" (76-102cm)	34" (86cm)

3. Mark the locations of the four mounting holes and the conduit entrance location on the wall. (The conduit entrance is the proper hole diameter for 1/2 inch (13mm) conduit.)

4. Fasten the backplate to the wall where previously marked.

RECOMMENDATION:

Wood wall – No. 16 (M8) wood screws, 2 3/4" (70mm) long

Cement or brick – 1/4" (M6) stud expansion bolts, 3" (76mm) long

Hollow wall – 1/4" (M6) toggle bolts, length depends on wall thickness

5. Run service wire to the dryer location and connect to the terminal block. **IMPORTANT:** All units must be supplied with 3 wire service. Use No. 12 wire or larger, as required by local electrical code. The ground wire must be connected to the dryer backplate. Unit must be installed by a qualified licensed electrician.

CONNECT TO A DEDICATED CIRCUIT NOT TO EXCEED 20 AMPS.

Dryers located in shower rooms or other wet locations should be equipped with ground fault interrupter(s).

6. **Carefully** replace the cover using two tamper-proof bolts supplied, turn counter-clockwise. Be careful not to damage circuit board or sensor. Apply a bead of caulk around the edge of the cover to the wall.



AMERICAN DRYER, INC.

12932 FARMINGTON ROAD, LIVONIA, MI 48150, U.S.A.

Telephone (734) 421-2400 • Fax (734) 421-5580

www.americandryer.com • Email: sales@americandryer.com

Revised December 2009

OWNER'S MANUAL

"A-T" Series HAND AND HAIR DRYERS

**FOR INSTALLATION OR SERVICE
ASSISTANCE PLEASE CALL**

(734) 421-2400 OR

Email: sales@americandryer.com

IMPORTANT: HAVE MODEL & SERIAL NO. READY
MODEL # _____ **SERIAL #** _____

AMERICAN DRYER LIMITED WARRANTY - "A"

All dryer parts are warranted to the original consumer purchaser to be free from defects in material and workmanship for a period of ten (10) years from the date of purchase from manufacturer, in the U.S.A. Outside of the U.S.A., two (2) years. The electronic sensor is warranted for five (5) years. Outside of the U.S.A., two (2) years. We will replace **FREE OF CHARGE**, during the warranty period, any warranted part which proves defective in material and/or workmanship under normal installation, use, and service, excluding normal wear. Replacement parts can be obtained by returning the part, **TRANSPORTATION CHARGES PREPAID**. You must notify factory prior to returning part or dryer. Any damage to this dryer as a result of misuse, abuse, neglect, accident, improper installation, unauthorized repairs, or any other use violative of instructions furnished by us, **WILL VOID THIS WARRANTY. THIS WARRANTY IS IN LIEU OF ANY AND ALL WARRANTIES, EXPRESS OR IMPLIED, AND IS LIMITED TO THE REPLACEMENT OF DEFECTIVE PARTS ONLY. LABOR CHARGES AND/OR DAMAGE INCURRED IN INSTALLATION OR REPLACEMENT AS WELL AS ALL INCIDENTAL AND CONSEQUENTIAL DAMAGES CONNECTED THEREWITH ARE EXCLUDED.**

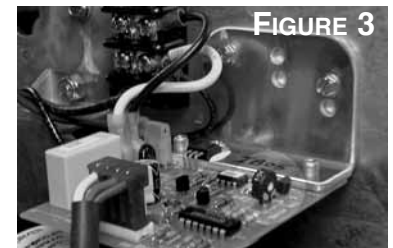
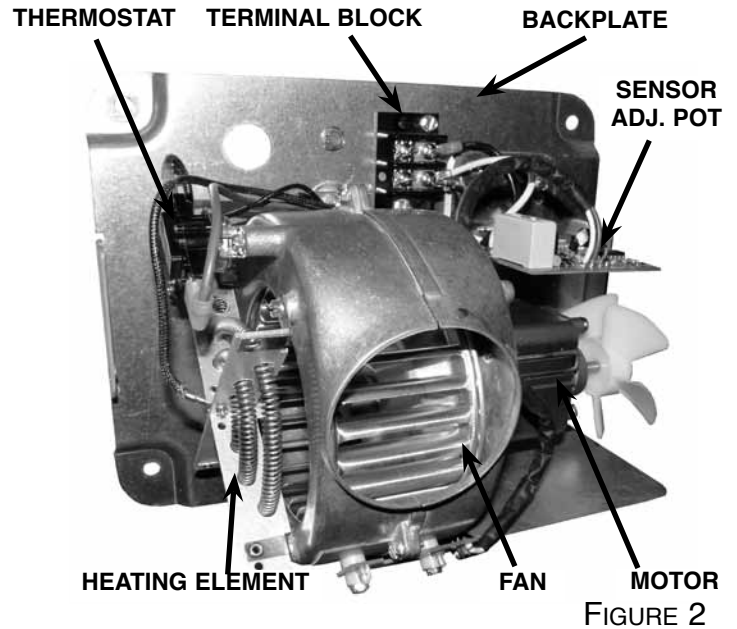
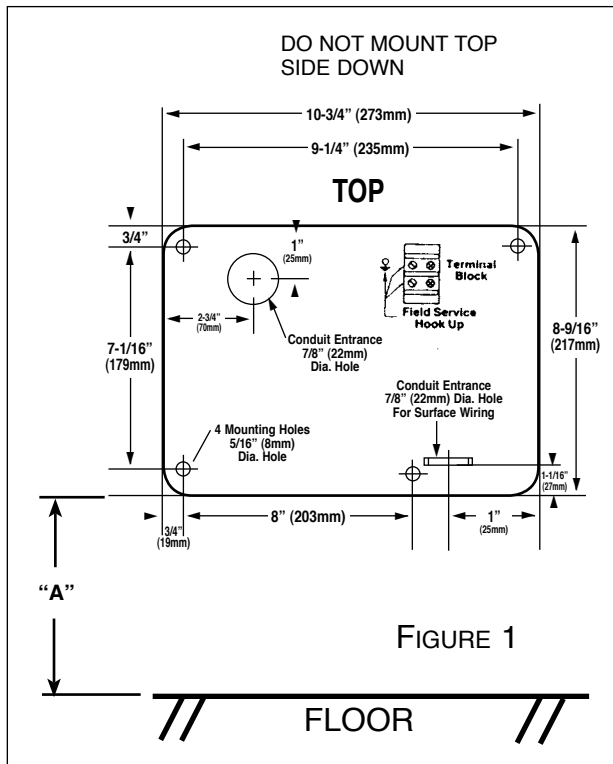

SENSITIVITY ADJUSTMENT

WARNING: DISCONNECT POWER BEFORE SERVICING
DESUNA LA ELECTRICIDAD ANTES DE HACER REPARACIONES

PARTS LIST FOR "A-T" MODELS

DR227 THERMOSTAT (CIRCUIT BREAKER)
 SP216C MOTOR, 115V, 60 HZ (A60, A70)
 SP217C MOTOR, 208-240V, 60 HZ (A80)
 CI232 SECURITY SCREW & SPECIAL ALLEN WRENCH
 DR239-P SENSOR COMPLETE, 110-240 VOLT
 DR218 HEATING ELEMENT (A60)
 DR219 HEATING ELEMENT (A70)
 DR220 HEATING ELEMENT (A80, A50)

CI202 COVER, MUST SPECIFY MODEL #, PUSH
 BUTTON OR AUTOMATIC.
 COMPLETE WITH ACCESSORIES.

SERVICE AND MAINTENANCE OF YOUR DRYER

Each component used in your dryer has been designed to provide years of trouble free service. However, if trouble should develop, it can normally be located by visual examination. Removal or replacement of most parts is simple and can be done without special tools.

IF COLD AIR IS COMING FROM THE NOZZLE:

Remove the cover and check the heating element. If the element is broken or burned out, replace it.

IF NO AIR IS COMING FROM THE NOZZLE AND HEATING ELEMENT GLOWS:

Remove the cover and check to see that the fan revolves freely. Check and replace motor, if required.

IF NO AIR IS COMING FROM THE NOZZLE AND HEATING ELEMENT IS NOT IN OPERATION:

Check the thermostat. Assuming the thermostat is okay the timer or sensor should be replaced.

AUTOMATIC DRYERS:

Check that circuit board and sensor are clean from dust and lint (carefully dust off). Make sure plastic window is clean on both sides. Foam piece on window must remain intact. When replacing dryer cover, be careful not to damage circuit board or sensor.

This dryer is activated by an infrared sensor. Hand dryers operate as long as hands are below nozzle. There is a maximum 80 second running time with a safety over-ride feature, if hands are not removed. Hair dryers turn on for 80 seconds by waving hands under the nozzle. Sensitivity is adjustable (FIGURE 3) by CAREFULLY turning the adjustment pot located on the sensor. Use a small flat blade screw driver. 1/3 Turn MAX. Turn CLOCKWISE to INCREASE sensitivity, COUNTER-CLOCKWISE to DECREASE sensitivity.

FOR ANY OTHER PROBLEM, CONTACT FACTORY FOR ASSISTANCE.

CLEANING - DO NOT spray cleaning solvents thru dryer vents. DO NOT use abrasive, chlorinated, or highly alkaline cleaners. DO NOT use oil based cleaners.

SEMI-ANNUALLY remove the cover and clean all lint and dust from the mechanism, inside of cover, and plastic window.

Clean cover with a mild soap or detergent and warm water, using a soft cloth or sponge.